

PARTS LIST

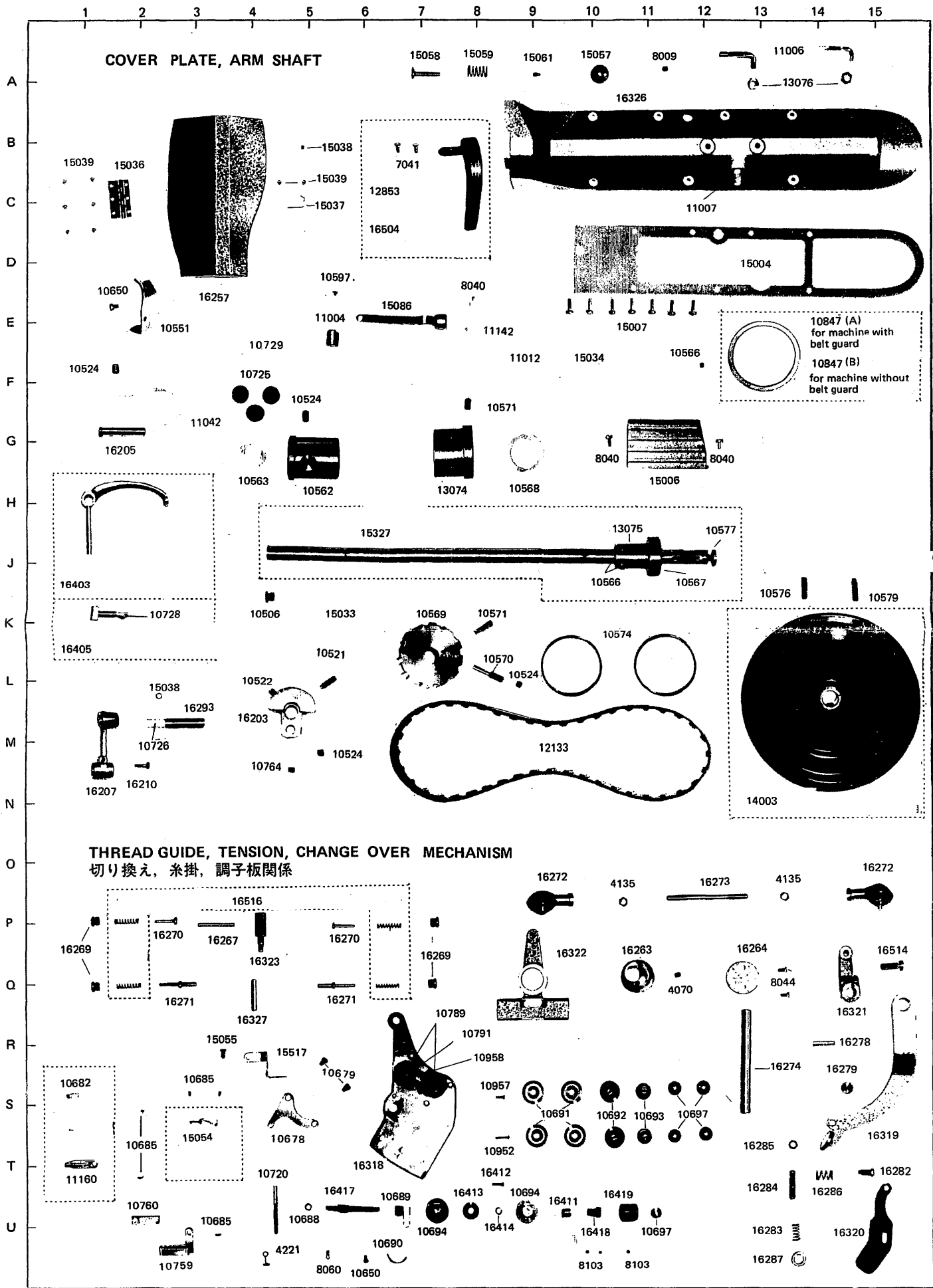

COVER PLATE, ARM SHAFT

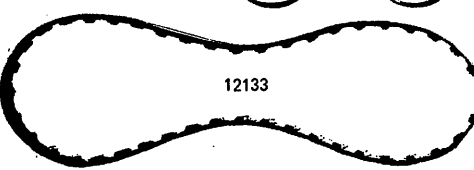
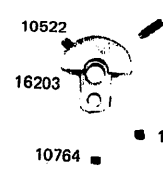
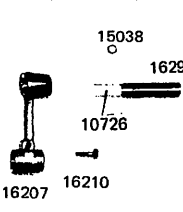
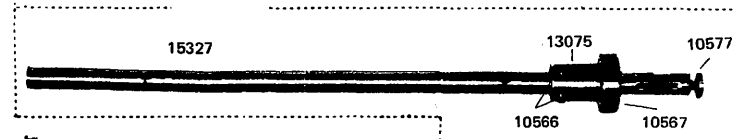
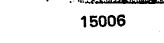
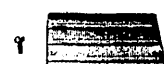
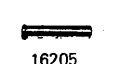
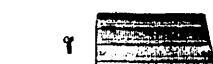
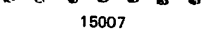
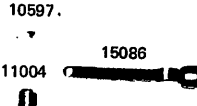
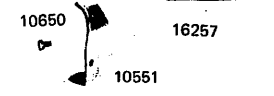
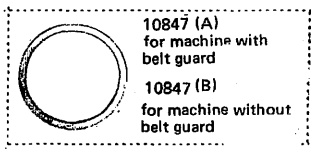
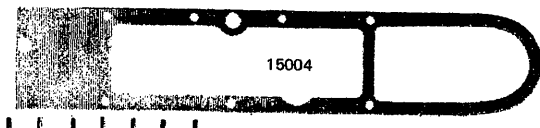
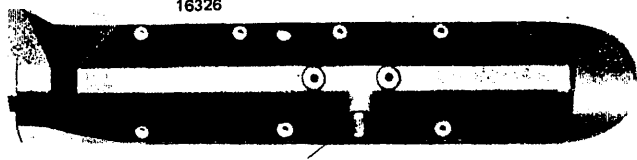
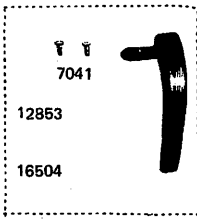
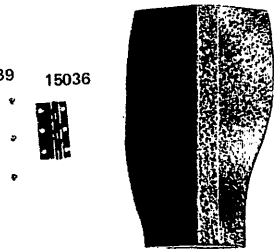

THREAD GUIDE, TENSION, CHANGE OVER MECHANISM 切り換え, 糸掛, 調子板関係

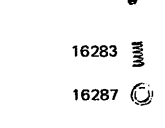
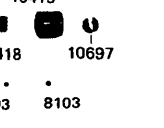
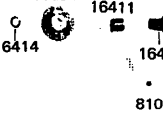
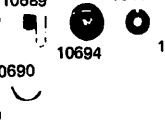
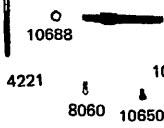
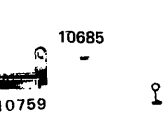
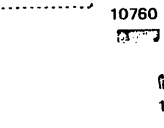
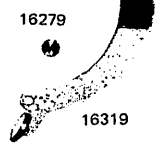
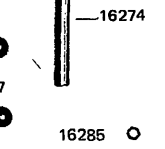
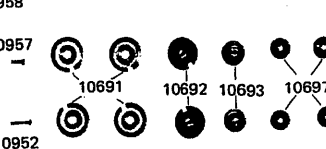
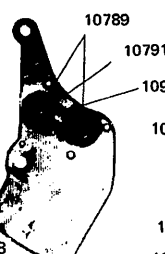
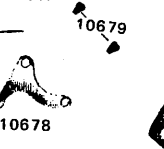
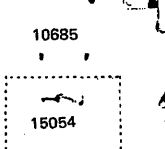
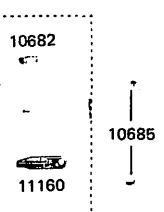
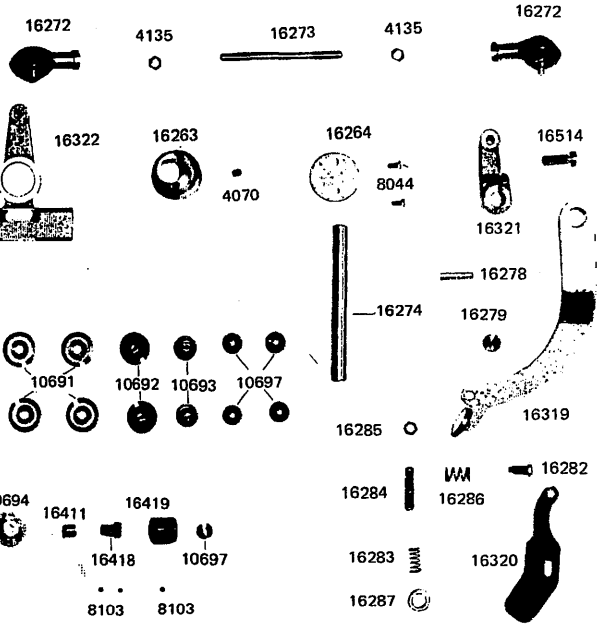
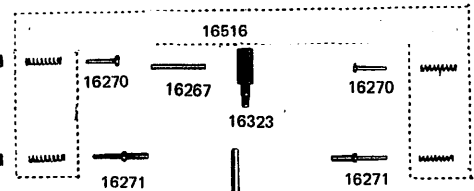

NEEDLE BAR MECHANISM

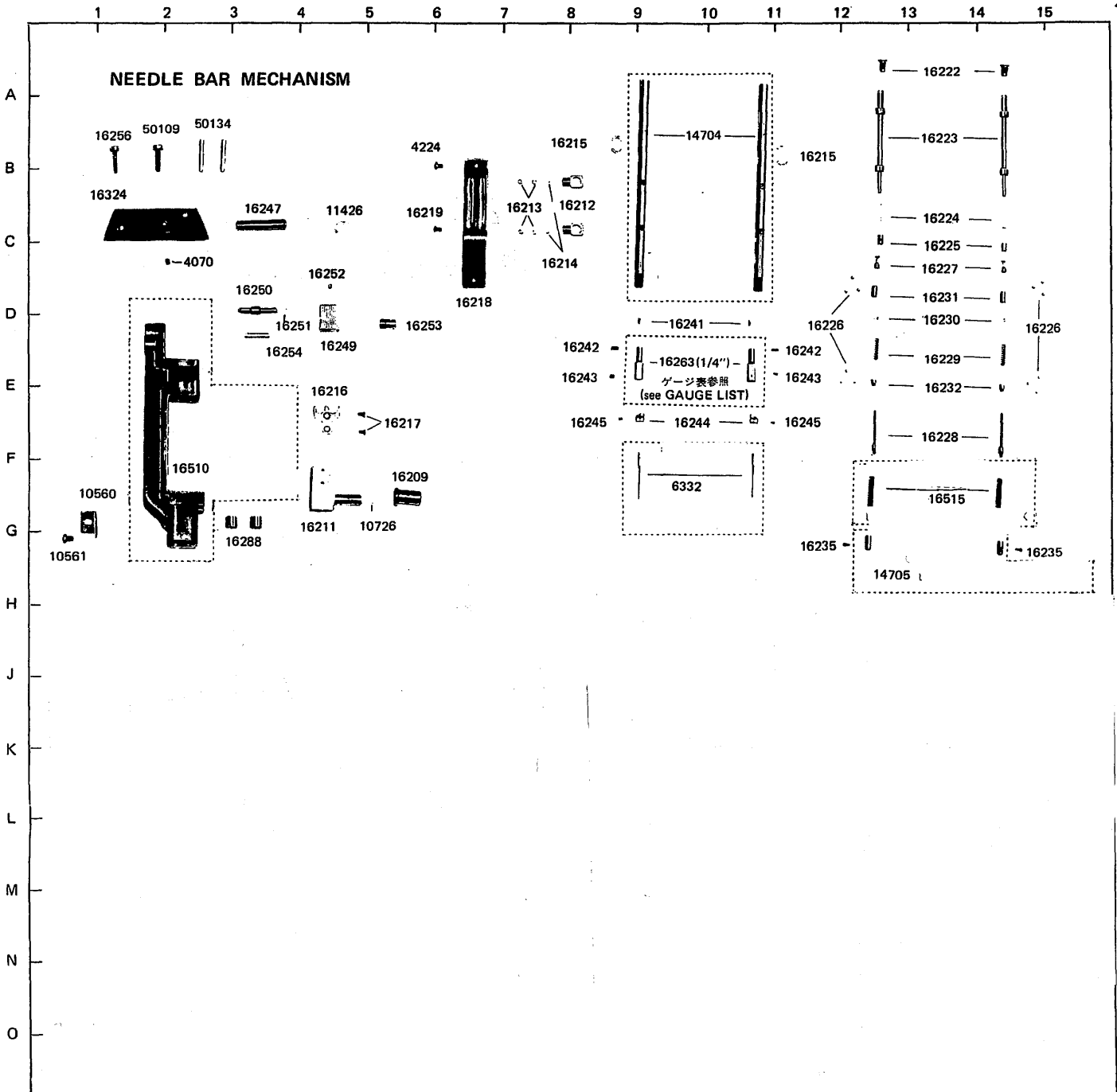

PRESSER BAR MECHANISM

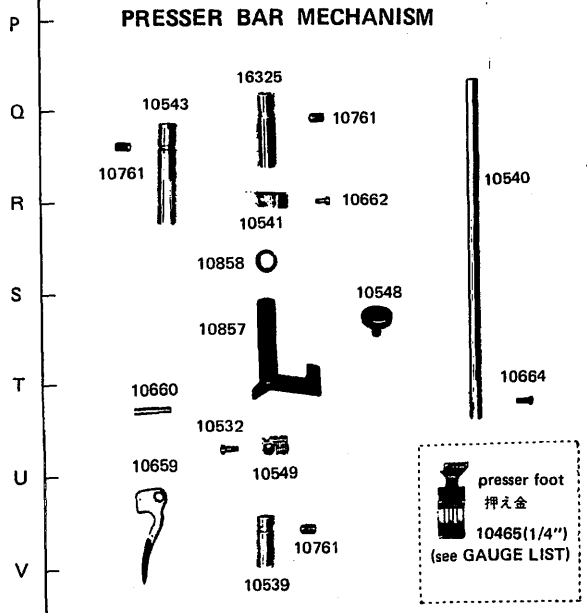

KNEE LIFTER LIFTING LEVER CONNEC TING ROD

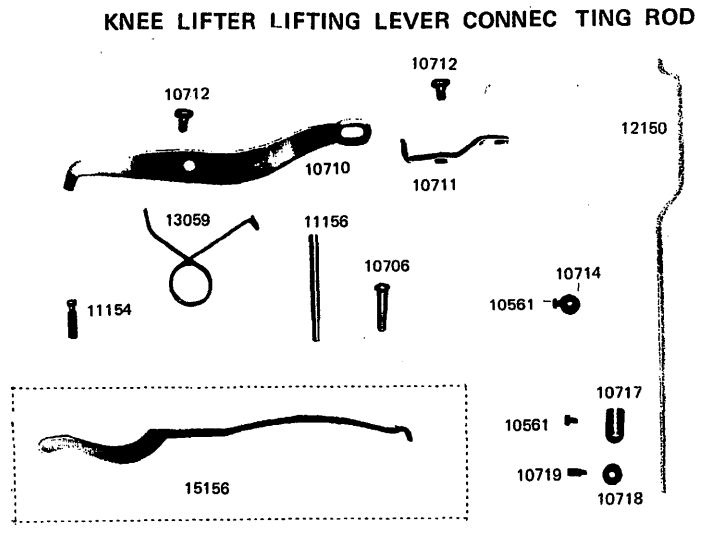

1 2 3 4 5 6 7 8 9 10 11 12 13 14 15

A B C D E F G H J K L M N O P Q R S T U V

LOWER SHAFT FEED MECHANISM

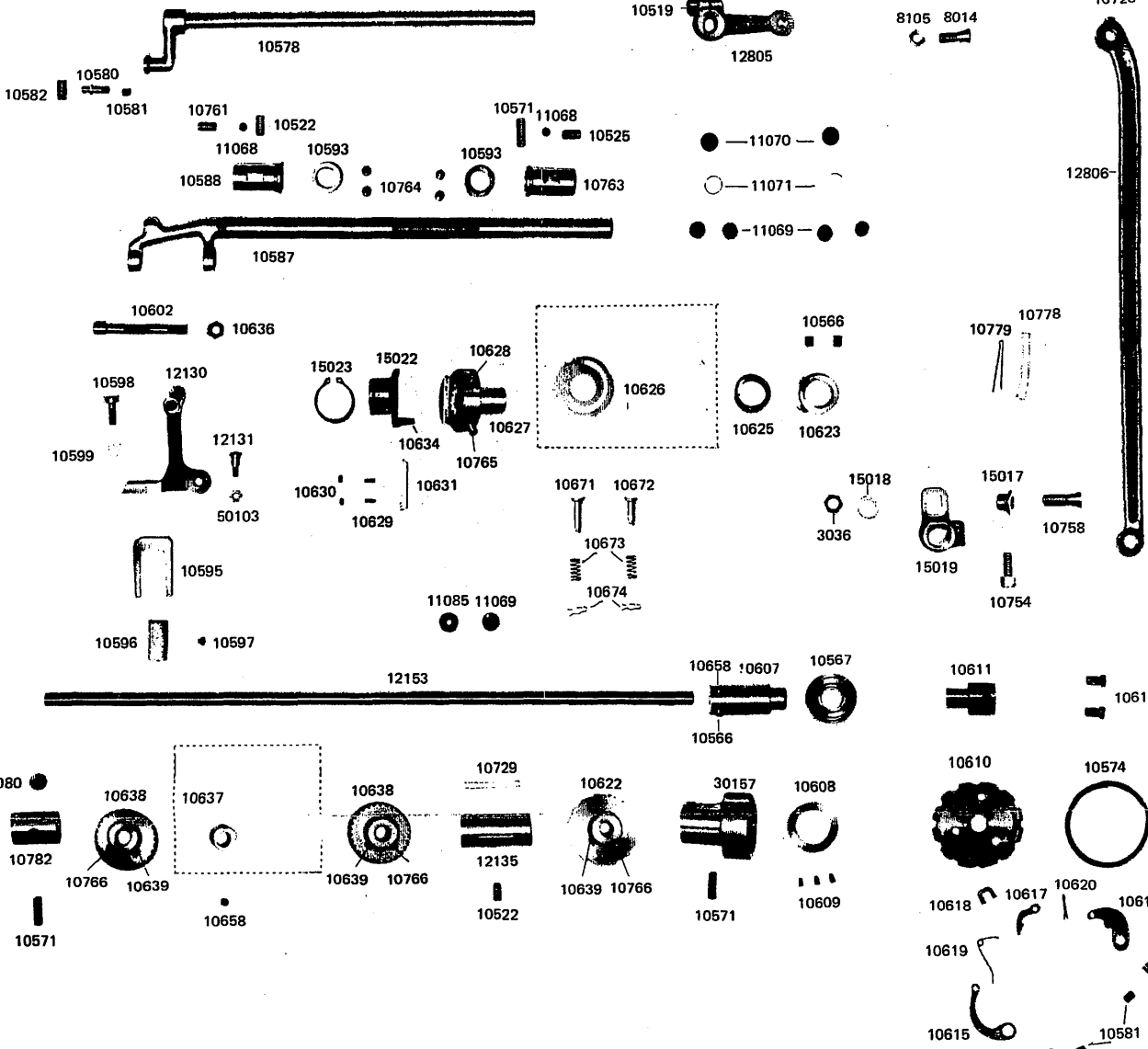

REVERSE STITCH MECHANISM

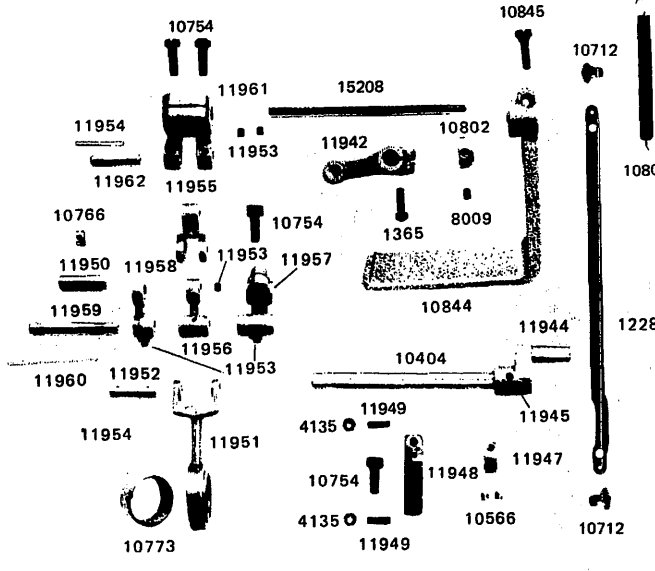

OIL WICK FOR BED

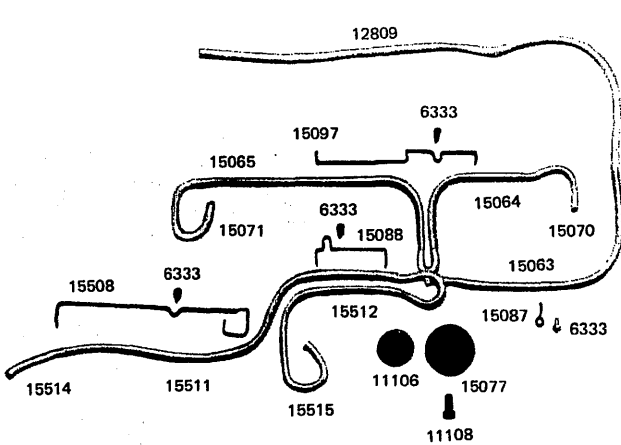

FEED DOG LEVER POST, HOOK SADDLE MECHANISM

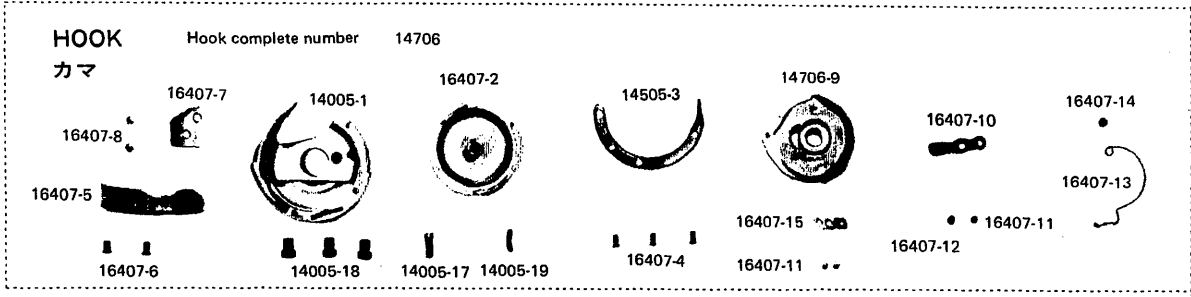
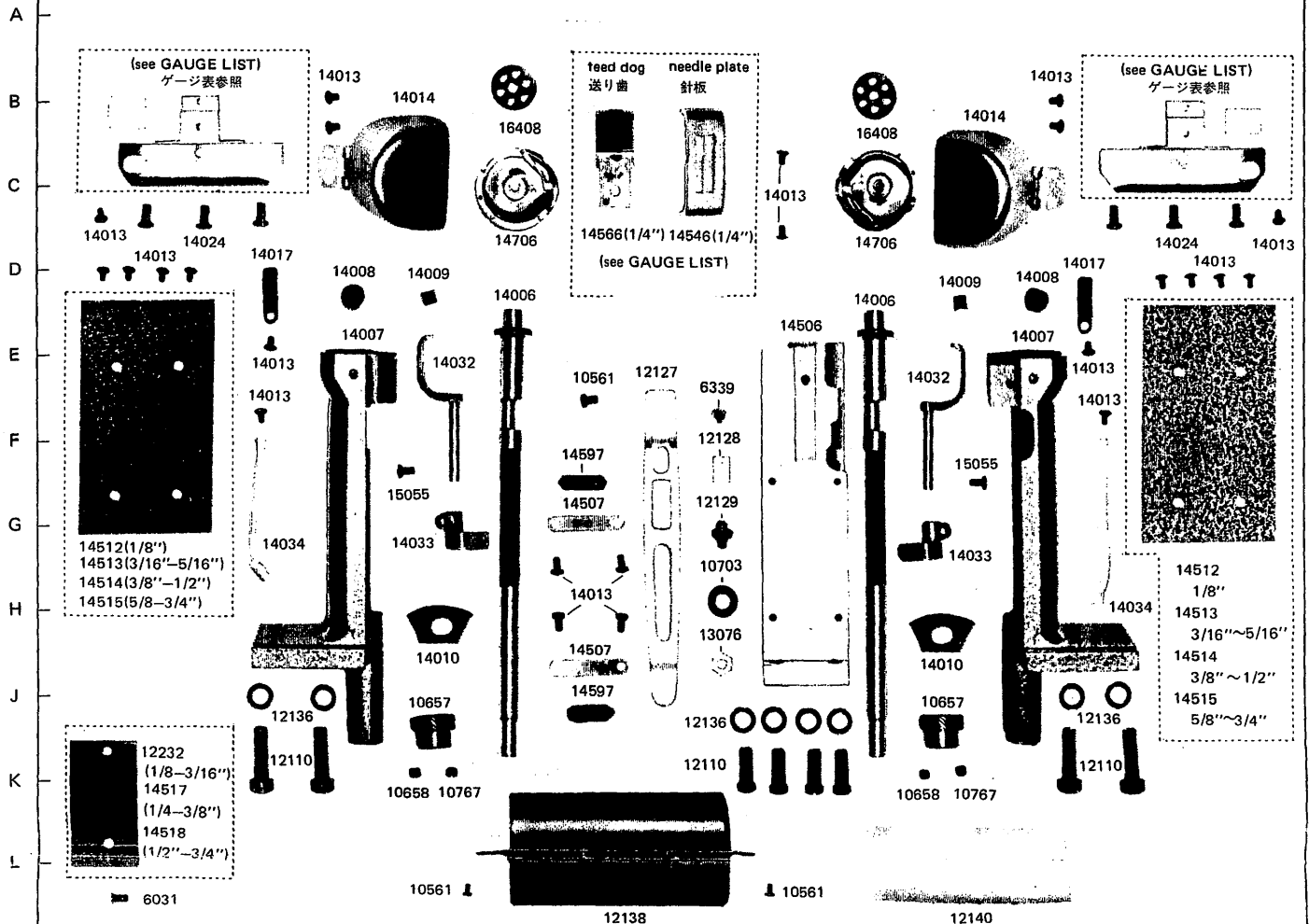

GAUGE LIST

needle clamp 針株	needle plate 針板	feed dog 送り歯	base for needle plate 針板受台	base plate for needle plate 針板下板	presser foot 押し金
16295 (1/8")	14543 (1/8")	14563 (1/8")	14508 (1/8")	14523 (1/8")	14583 (1/8")
16296 (3/16")	14545 (3/16")	14565 (3/16")	14509 (3/16" - 3/8")	14525 (3/16")	14585 (3/16")
16297 (7/32")	14554 (7/32")	14574 (7/32")	14510 (1/2" - 3/4")	14534 (7/32")	14594 (7/32")
16236 (1/4")	14546 (1/4")	14566 (1/4")		14526 (1/4")	14586 (1/4")
16237 (5/16")	14547 (5/16")	14567 (5/16")		14527 (5/16")	14587 (5/16")
16238 (3/8")	14548 (3/8")	14568 (3/8")		14528 (3/8")	14588 (3/8")
16239 (1/2")	14549 (1/2")	14569 (1/2")		14529 (1/2")	14589 (1/2")
16303 (5/8")	14550 (5/8")	14570 (5/8")		14530 (5/8")	14590 (5/8")
16304 (3/4")	14551 (3/4")	14571 (3/4")		14531 (3/4")	14591 (3/4")

1 2 3 4 5 6 7 8 9 10 11 12 13 14 15

BELT GUARD (Optional Equipment)

A
B
C
D
E
F
G
H
J
K
L
M
N
O
P
Q
R
S
T
U
V

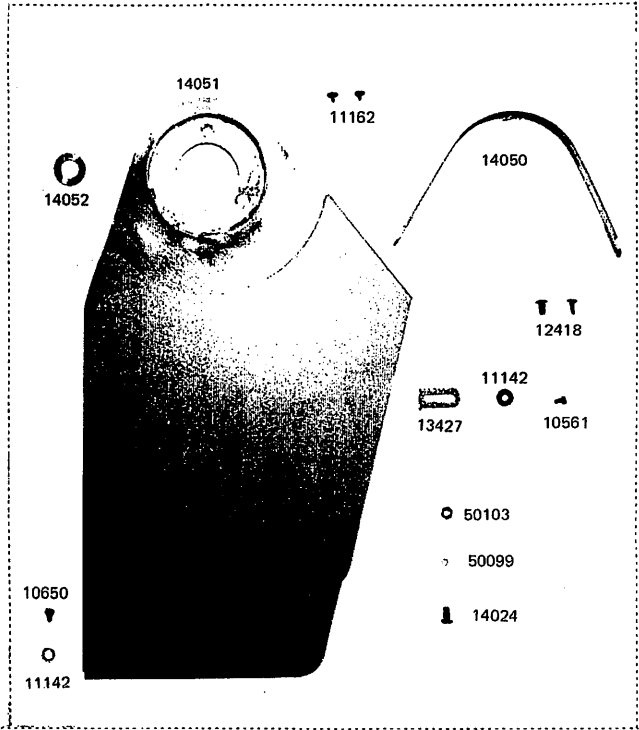

ACCESSORIES

